

FLEXIBLE BUMP STOPS *BUTÉES*

Primary suspension
Suspension Primaire

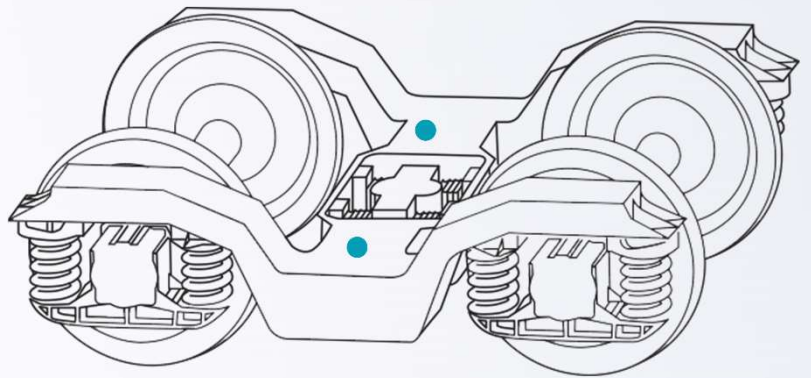

- » Bump stops are particularly adapted for flexible excursion limitation and the absorption of shocks on the bogie (transversal and longitudinal stops) as well as for limit stops in general.
- » Bumpers show progressive reaction curves.

- » *Les butées opposent un effort de réaction progressif lors des sollicitations.*

Fig. A
M2910

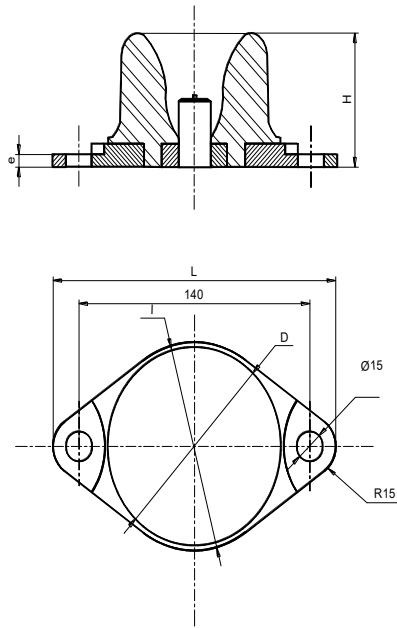

Fig. B
M2911

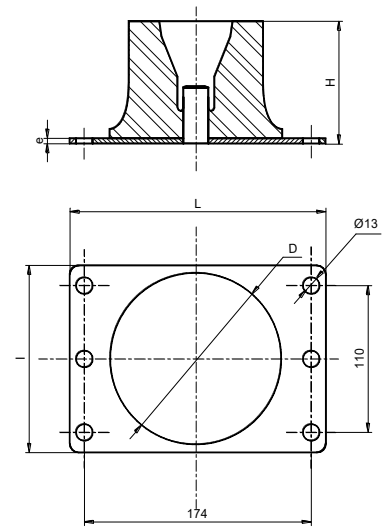

Fig. C
M2915

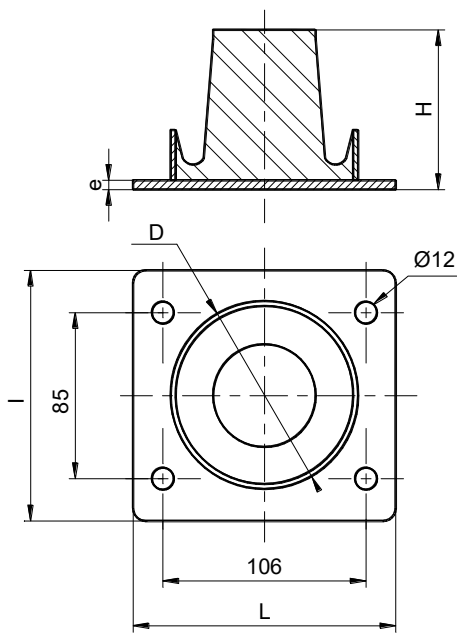
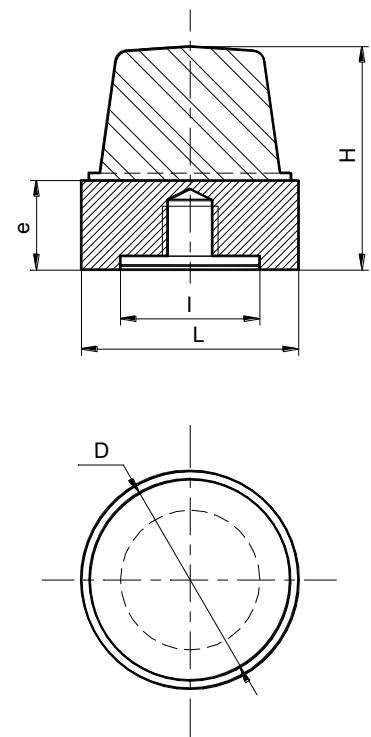

Fig. D
M2529
M2912
M2916



Reference	Fig.	H	D	L	l	e	Fc	dc	Sliding plate
		mm	mm	mm	mm	mm	daN	mm	
M2529	D	85	70	70	50	10	1035	23	•
M2910	A	68	101	170	110	12	-	-	•
M2911	B	85	130	196	140	5	-	-	•
M2912	D	70	72	128	40	22	1200 +/- 240	13,4	•
M2915	C	85	110	140	130	5	-	-	•
M2916	D	80	72	78	50	32	1200	13,4	•